

PENBERTHY SIGHT FLOW INDICATORS

ANSI 150, 300 and 600 pressure class sight flow indicators are the industry standard for common or powering process flow stream pressures.



FEATURES

- No power or special installation requirements.
- Available with threaded or flanged connections.
- Four indication styles available.
- Single piece cast body.
- Wide variety of special materials to suit the most diverse applications.
- Lined units available to satisfy most corrosive environments.
- Single, inexpensive means of monitoring flow.
- Visible indication allows flow characteristic to be observed.
- Instrument taps allow insertion of additional monitoring equipment.

*Product images are for reference only, please refer to general or approval drawings for accurate dimensions.

GENERAL APPLICATION

These ANSI rated units are used in power piping, refrigeration, petroleum, petrochemical and general process industries.

TECHNICAL DATA

Body Materials:	Bronze, carbon steel, stainless steel, Alloy 20
Sizes Threaded:	¼" to 2" (DN 8 to 50)
Sizes Flanged:	½" to 8" (DN 15 to 200)
Connections	
SF/DW:	Threaded NPT or flanged
SM/SH:	Threaded NPT or flanged
STW:	Threaded Window NPT
Pressure range:	Up to 1480 psig
Temperature range:	-325°F (-199 °C) to 500°F (260°C)



16633 Foltz Parkway, Strongsville, OH 44149 USA • Telephone: +440-572-1500
www.penberthyprocess.com • sales@penberthyprocess.com

PENBERTHY SIGHT FLOW INDICATORS

OVERVIEW

SIGHT FLOW INDICATORS

Sight flow indicators provide a window into piping. The process flow stream can be monitored by observation through the glass window. Special mechanisms can be mounted in most sight flow indicator models to enhance visibility when observing a liquid.

The four basic components of sight flow indicators are:

Body: provides in-line attachment capability and rigidity to the sight flow indicator.

Glass: provides the viewing window to the process flow stream.

Gasket: compresses to seal the gap tightly and prevent leaking between the glass, body, and cover.

Cover: provides compression surface for the bolts to hold the gasket and glass tightly against the sight flow body.

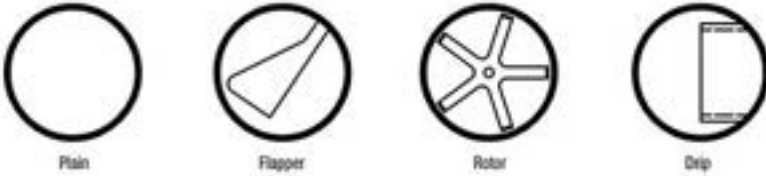
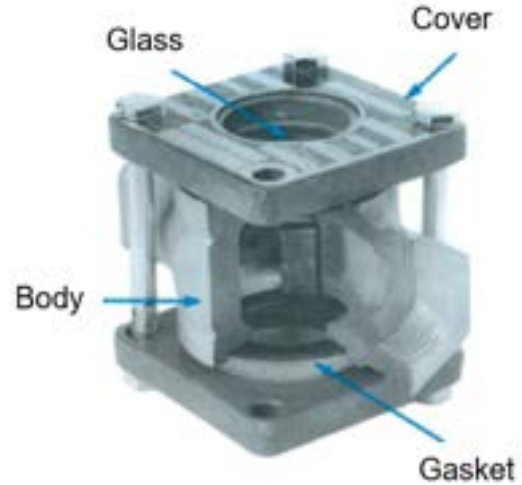

There are four basic indicator types:

Plain

A plain sight flow indicator can be used in a liquid application where there is a visual contrast between the liquid presence and its absence. Contrast in the forms of color, tint, hue, clarity or turbulence indicates variation in flow. Any orientation of flow can be observed.

Flapper

A flapper sight flow indicator can be used in a liquid application where there is a great enough liquid mass impact to move the weight of the flapper. A hinged flapper indicated variation in flow by its position. Transparent or slightly opaque fluids can be monitored. Horizontal and vertically upward flow can be observed.

Rotator

A rotator sight flow indicator can be used in a fluid application where there is great enough liquid mass impact to spin the PTFE rotator paddle wheels. A spinning motion indicates variation in flow, ideal for darker color solutions where color contrast is better, translucent liquids and clear solutions. Any orientation of flow can be observed.

Drip tube

A drip tube sight flow indicator can be used in a fluid application where there is formation of liquid droplets. Condensation collecting on the tube indicates variation in flow. Distillation and similar processes with intermittent flow can be monitored. Horizontal and vertically downward flow can be observed.



*Product images are for reference only, please refer to general or approval drawings for accurate dimensions.

PENBERTHY SIGHT FLOW INDICATORS

FLUOROPOLYMER LINED SIGHT FLOW INDICATORS

These lined sight flow indicators can safeguard against chemical reactions in corrosive environments.

Lined sight flow indicators are designed for viewing corrosive media. Except for the borosilicate glass, the lining of the indicator covers all otherwise wetted parts. The lining provides protection from attack by chemicals and solvents which can cause rapid deterioration of standard plastics and common metals. Lined bodies are available with plain, drip-tube or single-sheet flutter flapper indicators.

Fluoropolymer resins are essentially chemically inert. The only known chemicals that react with them are molten alkali metals, turbulent fluorine and a few fluoro-chemicals and halogenated organic chemicals. Lined bodies are available with drip tube and flutter flapper style indicators. With lining the body can only be constructed of iron. Pressure and temperature ratings are shown on the graph at the right.

Specialty fluoropolymer resin is inert to strong mineral acids, inorganic bases, halogens and metal salt solutions. The material is ineffective with organic bases and very strong oxidizing acids near their boiling point. Consult the factory to obtain information about chemical use/temperature guide.

Specialty fluoropolymers have excellent mechanical strength, stiffness and abrasion resistance and an effective temperature range from -370°F (-223 °C) to 300°F (150°C). Linings are available in all Penberthy sight flow indicator plain flanged bodies 1" or larger. Pressure and temperature ratings will depend on materials of construction and sight flow indicator model selected.

LINED DUCTILE IRON

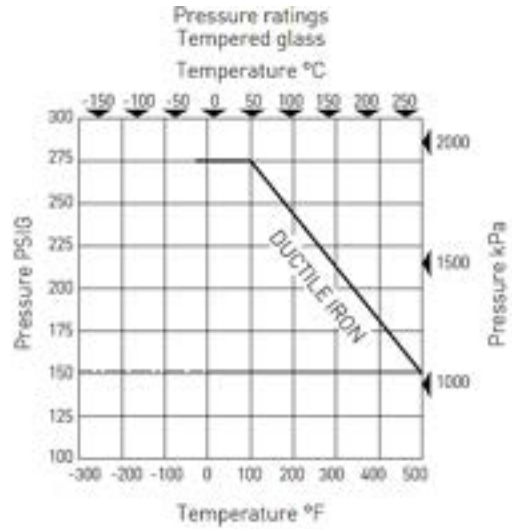

Lined Iron

Lined Steel and Stainless

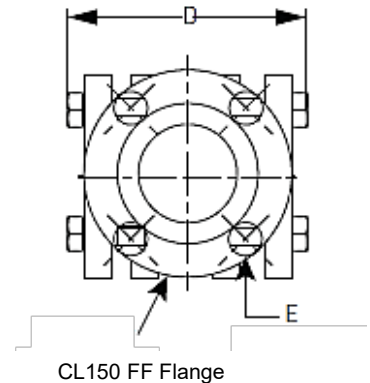
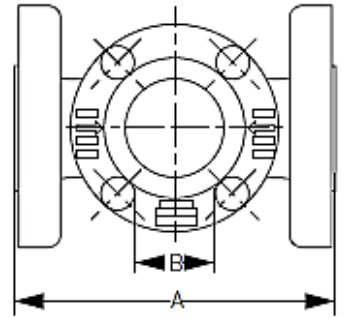

*Product images are for reference only, please refer to general or approval drawings for accurate dimensions.

LINED IRON DIMENSIONS

Unit Size	Dimensions									
	A		B		C		D		E	
	in.	cm	in.	cm	in.	cm	in.	cm	in.	cm
1	7	17.8	1 1/2	3.8	1	2.5	4 5/8	11.7	5/8	1.6
1 1/2	8	20.3	2 3/8	6.0	1 1/2	3.8	5 5/8	14 1/3	5/8	1.6
2	9	22.9	2 7/8	7.3	2	5.1	6 5/8	16.8	3/4	1.9
3	11	27.9	3 3/4	9.5	3	7.6	8 1/4	21.0	3/4	1.9
4	13	33.0	4 3/4	12.1	4	10.2	9 1/4	23.5	3/4	1.9
6	16	40.6	7	17.8	6	15.2	12 3/4	32.4	7/8	2.2
8	18	45.7	9	22.9	8	20.3	16 1/8	41.0	7/8	2.2



ANSI 150 PRESSURE CLASS SIGHT FLOW INDICATORS

Series SF

The industry standard for common process flow stream pressures

Available in NPT threaded-end and flanged designs, these sight flow indicators meet most standard installation requirements. Made from single-piece cast-construction bodies, these SFIs are available with all four styles of Penberthy indication.

Models:

- SF: NPT SFI (plain)
- SFF: NPT SFI (Flapper)

- SFR: NPT SFI (rotator)
- SFD: NPT SFI (drip tube)
- SF-F: Flanged SFI (plain)
- SFR-F: Flanged SFI (rotator)
- SFD-F: Flanged SFI (drip tube)

Optional:

- ASTM 494 Monel® gr. M-30C
- ASTM A494 Hastelloy® C CW12MW
- ASTM A351 Alloy 20 CN7M
- Consult factory for other materials.

Materials of construction for body

- Standard:
- ASTM A395 Gr. 60 – 40 – 18 Ductile Iron
- ASTM B61 Bronze
- ASTM A216 steel gr. WCB
- ASTM A351 316L/316 STS gr. CF3M/CF8M

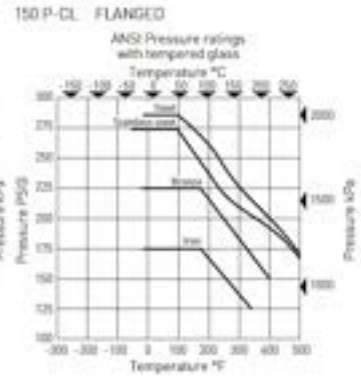
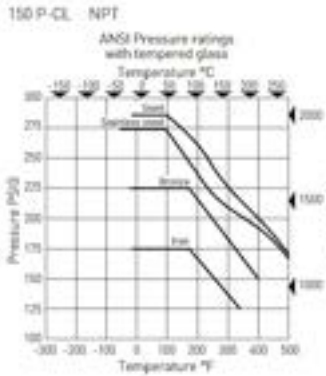
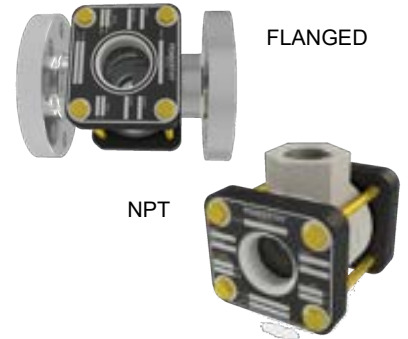

*Product images are for reference only, please refer to general or approval drawings for accurate dimensions.

150 P-CL NPT DIMENSIONS

Unit Size	Dimensions									
	A		B		C		D		E	
	in.	cm	in.	cm	in.	cm	in.	cm	in.	cm
1/4	3	7.6	13/16	2.1	1 1/8	2.9	3 1/2	8.9	1/4	0.6
3/8	3	7.6	13/16	2.1	1 1/8	2.9	3 1/2	8.9	3/8	1.0
1/2	3 3/4	9.5	1 1/4	3.2	1 1/2	3.8	4	10.2	1/2	1.3
3/4	3 3/4	9.5	1 1/4	3.2	1 1/2	3.8	4	10.2	3/4	1.9
1	4 1/4	10.8	1 1/4	3.2	1 3/4	4.4	4 1/2	11.4	1	2.5
1 1/4	5 1/2	14.0	2	5.1	2 5/8	6.7	5 3/4	14.6	1 1/4	3.2
1 1/2	5 1/2	14.0	2	5.1	2 5/8	6.7	5 3/4	14.6	1 1/2	3.8
2	6 1/4	15.9	2	5.1	3 1/8	7.9	6 3/4	17.1	2	5.1

150 P-CL FLANGED DIMENSIONS

Unit Size	Dimensions							
	A		B		C		D	
	in.	cm	in.	cm	in.	cm	in.	cm
1/2	4 5/8	11.7	1 1/8	2.8	1/2	1.3	4	10.2
3/4	4 5/8	11.7	1 1/8	2.8	3/4	1.9	4	10.2
1	5 5/8	14.3	1 1/4	3.2	1	2.5	4 1/2	11.4
1 1/4	6 1/2	16.5	2	5.1	1 1/4	3.2	5 7/8	14.6
1 1/2	6 1/2	16.5	2	5.1	1 1/2	3.8	5 7/8	14.6
2	7 7/8	20.0	2	5.1	2	5.1	6 1/4	15.2
2 1/2	9 3/8	23.8	3 1/5	8.1	2 1/2	6.4	8 1/2	20.3
3	9 3/8	23.8	3 1/5	8.1	3	7.6	8 1/2	20.3
4	11	27.9	4 3/8	11.1	4	10.2	10 1/2	26.0
6	14 1/4	36.2	6 7/8	17.5	6	15.2	14 3/4	34.3
8	16 1/8	41.0	8 1/4	21.0	8	20.3	17 1/2	41.9

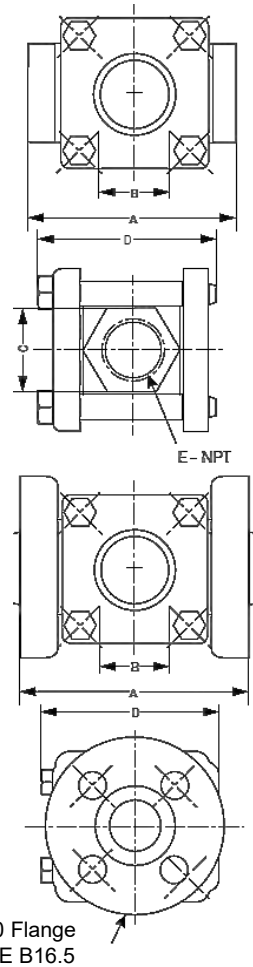

**ANSI 300 AND 600 PRESSURE CLASS
HIGH PRESSURE SIGHT FLOW
INDICATORS**

Available in flanged models only, these sight flow indicators meet tough ANSI standards for 300 and 600 pressure class requirements. Made from single-piece, cast-construction bodies, these SFIs are available with all four styles of Penberthy indication.

Models

300 pressure class series

- SM: NPT SFI (plain)
- SMF: NPT SFI (flapper)
- SMR: NPT SFI (rotator)
- SMD: NPT SFI (drip tube)
- SM-F: Flanged SFI (plain)
- SMF-F: Flanged SFI (flapper)
- SMR-F: Flanged SFI (rotator)
- SMD-F: Flanged SFI (drip tube)

600 pressure class series

- SH: NPT SFI (plain)
- SHF: NPT SFI (flapper)
- SHR: NPT SFI (rotator)
- SHD: NPT SFI (drip tube)
- SH-F: Flanged SFI (plain)
- SHF-F: Flanged SFI (flapper)
- SHR-F: Flanged SFI (rotator)
- SHD-F: Flanged SFI (drip tube)

High pressure sight flow indicator applications

Naturally occurring high pressure wells (natural gas, petroleum, geothermal steam) and long-distance pumping (transportation) of liquids and gases require high pressure sight flow indicators to observe fluid dynamics.

Chemical processes often require that fluids be in their liquid state. To achieve this, the chemical must remain under pressure at all times so that it can be transported using high pressure pumps. Observing the flow of chemicals such as Argon, Hydrogen, Nitrogen, Oxygen, Carbon Monoxide, Propane, Ethyl Methyl Ether, Butane, Isobutane, Pentane in their liquid state requires high pressure sight flow indicators.

Industrial areas where high pressure pipelines are used include:

- Power piping – Steam electric generation stations; industrial and institutional plants; central and district heating plants.
- Refrigeration piping.
- Petroleum – Petroleum refinery piping; loading terminal; gas metering; main and service lines; bulk plant and compressor stations compounding plant; storage facilities; gas pipelines.
- Agricultural/chemical – Alkylation/carboxylation; dehydration/halogenation; condensation/cyclization; other complex chemical conversions.

Materials of construction for body

Standard:

- ASTM A216 steel gr. WCB
- ASTM A351 316L/316 STS gr. CF3M/CF8M

Optional:

- ASTM 494 Monel® gr. M-30C
 - ASTM A494 Hastelloy® C CW12MW
 - ASTM A351 Alloy 20 CN7M
- Consult factory for other materials.



300 P-CL



600 P-CL

*Product images are for reference only, please refer to general or approval drawings for accurate dimensions.

ANSI 300 AND 600 PRESSURE CLASS HIGH PRESSURE SIGHT FLOW INDICATORS

300 P-CL

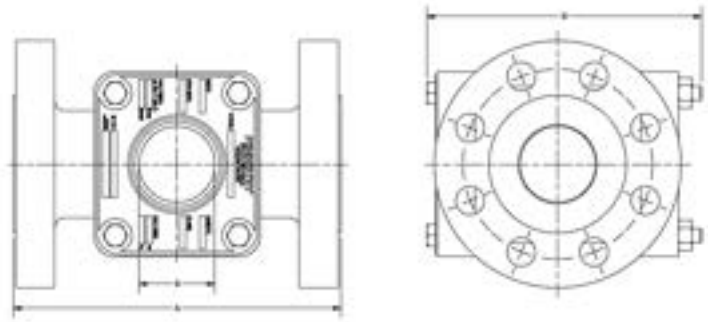
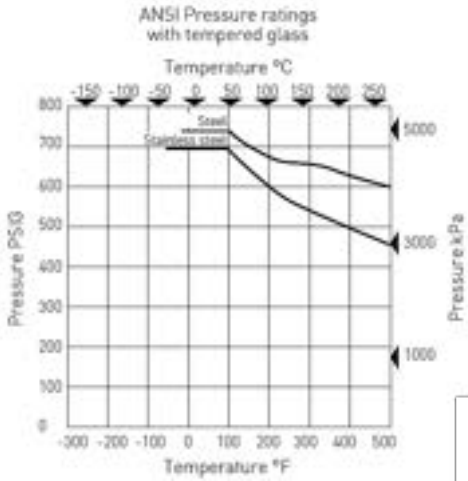

300 P-CL DIMENSIONS

Unit Size	Dimensions							
	A		B		C		D	
	in.	cm	in.	cm	in.	cm	in.	cm
1/2	5 7/8	14.9	1	2.5	1/2	1.3	5 1/4	13.3
3/4	5 7/8	14.9	1	2.5	3/4	1.9	5 1/4	13.3
1	6 7/8	17.5	1 1/4	3.2	1	2.5	5 1/4	13.3
1 1/4	7 1/2	19.1	2	5.1	1 1/4	3.2	7 3/8	18.7
1 1/2	7 1/2	19.1	2	5.1	1 1/2	3.8	7 3/8	18.7
2	8 5/8	21.9	2	5.1	2	5.1	7 5/8	19.4
2 1/2	11 3/8	28.9	3 3/16	8.1	2 1/2	6.4	10 5/8	27.0
3	11 3/8	28.9	3 1/16	8.1	3	7.6	10 5/8	27.0
4	13 1/4	33.7	4 1/4	10.8	4	10.2	13	33.0
6	21 3/8	54.3	5 1/2	14.0	6	15.2	17 1/8	43.5
8	22 3/8	56.8	5 1/2	14.0	8	20.3	19	48.3

600 P-CL

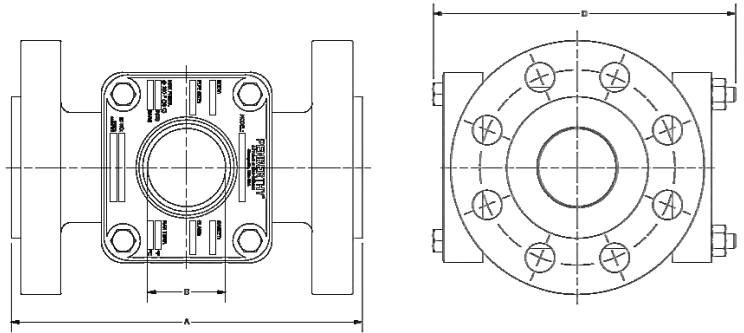
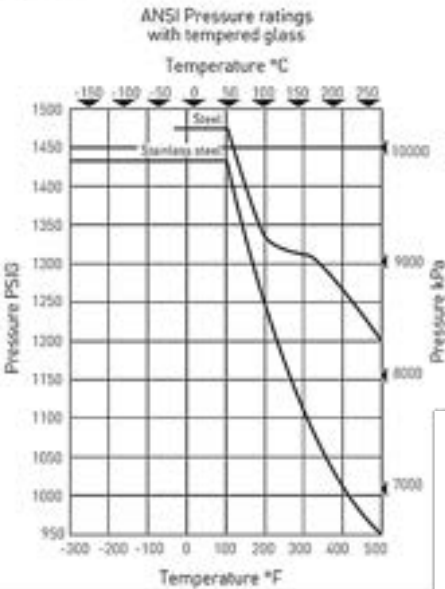

600 P-CL DIMENSIONS

Unit Size	Dimensions							
	A		B		C		D	
	in.	cm	in.	cm	in.	cm	in.	cm
1/2	6 1/4	15.9	1	2.5	1/2	1.3	5 1/4	13.3
3/4	6 1/4	15.9	1	2.5	3/4	1.9	5 1/4	13.3
1	7 1/4	18.4	1 1/4	3.2	1	2 1/2	5 3/4	14.6
1 1/4	7 7/8	20.0	2	5.1	1 1/4	3.2	5 7/8	14.9
1 1/2	7 7/8	20.0	2	5.1	1 1/2	3.8	5 7/8	14.9
2	9	22.9	2	5.1	2	5.1	8 1/8	29.5
2 1/2	11 3/4	29.8	3 3/16	8.1	2 1/2	6.4	11 5/8	29.5
3	11 3/4	29.8	3 3/16	8.1	3	7.6	11 5/8	29.5
4	14 1/4	36.2	4 1/4	10.8	4	10.2	14 1/4	36.2



DUAL-WINDOW SIGHT FLOW INDICATORS

Series DW

Added protection for pipeline systems in high traffic or confined areas

Dual-window sight flow indicators provide two glass discs on each side, so that if either glass should fail for any reason, the other window can withstand pressures temporarily until the unit can be repaired or replaced. Dual-window sight flow indicators and Factory Mutual System approved dual-window sight flow indicators are available in 150 pressure class NPT models and 150 and 300 pressure class flanged models.

Models

150 pressure class NPT dual-window

- DWF: Dual-window NPT SFI (plain)
- DWFF: Dual-window NPT SFI (flapper)
- DWFR: Dual-window NPT SFI (rotator)
- DWFD: Dual-window NPT SFI (drip tube)

150 pressure class flanged dual-window

- DWF-F: Dual-window flanged SFI (plain)
- DWFF-F: Dual-window flanged SFI (flapper)
- DWFR-F: Dual-window flanged SFI (rotator)
- DWFD-F: Dual-window flanged SFI (drip tube)

300 pressure class flanged dual-window

- DWM-F: Dual-window flanged SFI (plain)
- DWMF-F: Dual-window flanged SFI (flapper)
- DWMR-F: Dual-window flanged SFI (rotator)
- DWMD-F: Dual-window flanged SFI (drip tube)

Dual windows comprise two glass discs on each side held in position by a metallic housing, internal shims and gaskets.

The double, tempered glass window design provides added protection in applications where there is:

- External mechanical impact – if the outer glass is cracked or shattered, the inner glass can temporarily continue in service until the unit can be repaired or replaced.
- Abnormal compressive forces – in maintenance or replacement situations, the housing assists in alignment of the glass and can absorb uneven or excessive compression.
- Thermal shock – in high temperature applications, the inner and outer glass protect one another from an extreme thermal gradient. The air pocket between the glass provides an insulative effect.
- Corrosion – if the inner glass is weakened and it breaks, the outer glass can temporarily contain the fluid, withstand the pressure and continue in service until the unit can be repaired or replaced.

Materials of construction dual-window bodies

Standard:
 ASTM A216 steel gr. WCB*
 ASTM A351 316L/316 STS gr. CF3M*/CF8M

Optional:
 ASTM A494 Monel® gr. M-30C
 ASTM A494 Hastelloy® C CW12MW*
 ASTM A351 Alloy 20 CN7M

Gaskets:
 Grafoil®
 Garlock IFG-5500

Consult factory for other materials.

NOTE

*Materials of construction for dual-window 300 pressure class flanged body.

150 P-CL FLANGED



300 P-CL FLANGED



150 P-CL NPT



*Product images are for reference only, please refer to general or approval drawings for accurate dimensions.



THREADED WINDOW SIGHT FLOW INDICATORS

Series STW

A slender body with easy access windows is a popular alternative to traditional sight flow indicators

Threaded window sight flow indicators are labelled with the company logo as well as pressure and temperature ratings. Available in NPT threaded-end designs, all threaded window sight flow indicator sizes meet ANSI 150 pressure class standards. They are available with all four styles of Penberthy indication.

Models

- STW: NPT threaded window SFI (plain)
- STWF: NPT threaded window SFI (flapper)
- STWR: NPT threaded window SFI (rotator)
- STWD: NPT threaded window SFI (drip tube)

The windows are screwed into the single-piece cast sight flow body.

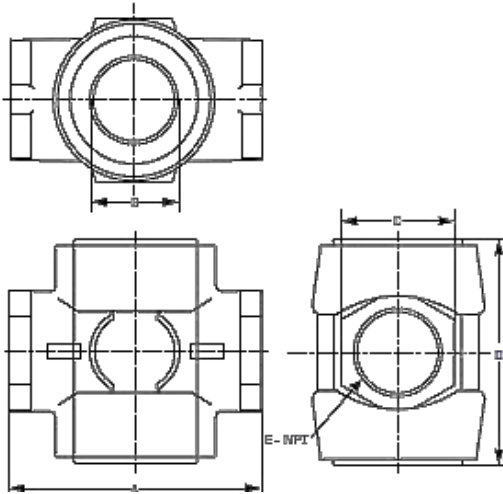

The threaded window design in an alternative style that is interchangeable with most applications using ANSI 150 pressure class sight flow indicators with bolt-on covers. Instead of unbolting the outer glass covers, these threaded windows are removed for cleaning or replacement with a spanner wrench.

Spanner wrenches for removing windows are available. The spanner wrenches have a 1/2" drive socket to be used with a torque wrench.

Materials of construction for all threaded window bodies

Standard:

- ASTM Bronze B61
- ASTM A216 steel gr. WCB
- ASTM A351 316L/316 STS gr. CF3M/CF8M

Optional:

- ASTM 494 Monel gr. M-30C
- ASTM A494 Hastelloy C CW12MW
- ASTM A734 Alloy 20 CN7M
- Consult factory for other materials.

Materials of construction for covers

Brass and 316 stainless barstock
All bodies are ANSI 150 pressure class regardless of size.

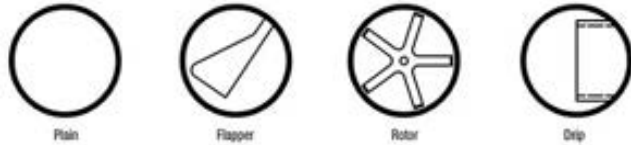

THREADED WINDOW SIGHT FLOW INDICATORS

Unit Size	Dimensions							
	A		B		C		D	
	in.	cm	in.	cm	in.	cm	in.	cm
1/4	3	7.6	4/5	2.1	2	5.1	1/4	0.6
3/8	3	7.6	4/5	2.1	2	5.1	3/8	1.0
1/	3 3/4	9.5	1 1/4	3.2	2 3/4	7.0	1/2	1.3
3/4	3 3/4	9.5	1 1/4	3.2	2 3/4	7.0	3/4	1.9
1	4 1/4	10.8	1 1/4	3.2	3 1/2	8.9	1	2.5
1 1/4	5 1/2	14	2	5.1	4 3/4	11.4	1 1/4	3.2
1 1/2	5 1/2	14	2	5.1	4 3/4	11.4	1 1/2	3.8
2	6 1/4	15.9	2	5.1	5	12.7	2	5.1

*Product images are for reference only, please refer to general or approval drawings for accurate dimensions.

AVAILABLE MATERIALS OF CONSTRUCTION

Ductile iron

ASTM A395 Gr 60-40-18

Carbon steel

ASTM A216 Gr WCB

ASTM A352 Gr LCB

Nickel alloys

ASTM A494/A494M Gr M-30C Monel

ASTM A494 Gr CW12MW Hastelloy C

ASTM A494 Gr N-12MV Hastelloy B

Stainless steel

ASTM A351 Gr CF3 (204/304L)

ASTM CF3M/CF8M

ASTM A351 316L/316

Bronze

ASTM B584 (B61) Alloy C92200

A351 Alloy 20 CN7M

Call factory for special material inquiries

Options

Socket weld connections; special material bolts and nuts; instrument plug; corrosion protection (paint, protector, STS fasteners).

Sight flow indicators can be made to conform to NACE MRO175 or MRO103 standards, consult factory.

Cushions

Garlock IFG-5500®

Shields

Mica

PCTFE (Kel-F®)

Glass discs

Borosilicate (tempered)

Quartz

UniGlas®

Gasket materials

Neoprene®

Garlock IFG-5500®

Buna N

PTFE (Teflon®)

FKM (Viton®)

Grafoil®

PCTFE (Kel-F®)

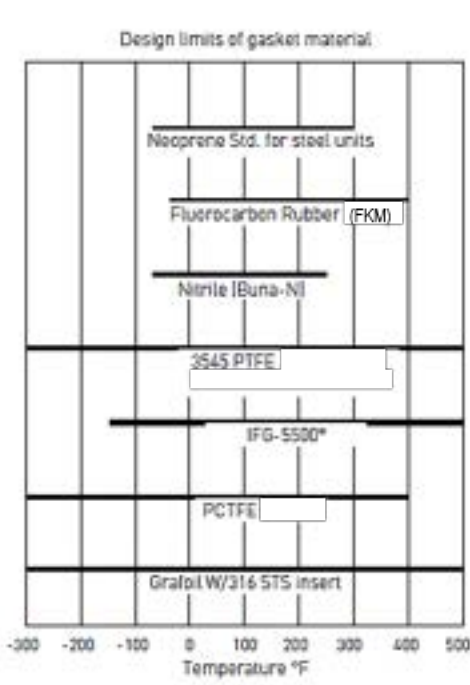

THREADED SIGHT WINDOW

A quick solution for pipe or tank observation

Available with brass or stainless steel retaining rings, these sight windows can be used anywhere that a 1/4" to 3" piping 'T' or a female NPT exists.

The Threaded Sight Windows are rated at ANSI 150 P-CL using tempered borosilicate glass.

Models

WTSL.....Threaded Sight Windows

The Threaded Sight Window is similar in design to the Threaded Window Sight Flow Indicator. The outer retaining ring compresses the glass between the gasket and cushion.

Spanner wrenches for window removal area available from Penberthy. The spanner wrenches have a 1/4" or 1/2" drive socket for torque wrench. All Threaded Sight Windows are machined from hex barstock.

Materials of construction for threaded glass housing

Hex Brass, Carbon Steel and Stainless Steel barstock. Consult factory for other material.



Spanner wrenches

CROSS REFERENCE GUIDE

Use Penberthy sight flow indicators or settle for second best. When designing a new process flow system or replacing an existing model, incorporate Penberthy models by using this cross reference chart and install with confidence.

Description	Penberthy	Jacoby-Tarbox	Papailias Co.
ANSI 150 P-CL SFI - Flapper	SFF	100-SA	FIS-F
ANSI 150 P-CL SFI - NPT Rotator	SFR	300-SA	FIS-R
ANSI 150 P-CL NPT - Drip Tube	SFD	200-SA	FIS-D
ANSI 300 P-CL High Pressure SFI	SM-F	F-910HPA-300	FIF-F/HP3
ANSI 600 P-CL High Pressure SFI	SH-F	F-910-HPA-600	FIF-F/HP6
ANSI 300 P-CL Dual window SFI-Flanged	DWM-F	F-910HPA-300-DW	-
ANSI 150 P-CL Dual window SFI-Flanged	DWF-F	910-FA-DW	-
ANSI 150 P-CL Dual window SFI-Flanged	DWF-F	100-SA-DW	-
Threaded window SFI - Flapper	STWF	100-ST	-
Threaded window SFI - Rotator	STWR	300-ST	-
Threaded window SFI - Drip tube	STWD	200-ST	-
Threaded sight window 150-P-CL	WTSL	S-5400	-

SPECIAL SIGHT FLOW INDICATORS

In addition to the broad standard range of sight flow indicators, Penberthy has the ability to create innumerable variants and unique solutions. Our metallurgy staff is capable of creating unique casting designs, with SFIs up to 16" having been produced.

Some industries require special connections with high precision machining needed to achieve the mandatory tight tolerances. We can use our skilled machinists to create a large variety of connection ends including butt-weld end connections. Flat surfaces are cast into bodies to provide for gaging and sampling ports.



PENBERTHY SIGHT FLOW INDICATORS

ORDERING INFORMATION - FLANGED SIGHT FLOW SELECTION GUIDE

Model		Size	Wetted Metal	Body	Indicator	Window	Gasket	Non-Wetted	Faceplate																																							
									5																																							
		<table border="1"> <thead> <tr> <th colspan="2">Class 150 ANSI</th> <th colspan="2">Class 300 ANSI</th> <th colspan="2">Class 600 ANSI</th> </tr> <tr> <th>Model</th> <th>Code</th> <th>Model</th> <th>Code</th> <th>Model</th> <th>Code</th> </tr> </thead> <tbody> <tr> <td>Plain</td> <td>SF-F TZA-</td> <td>SM-F TZH-</td> <td>SH-F TZN-</td> <td></td> <td></td> </tr> <tr> <td>Flapper</td> <td>SFF-F TZA-</td> <td>SMF-F TZH-</td> <td>SHF-F TZN-</td> <td></td> <td></td> </tr> <tr> <td>Drip Tube</td> <td>SFD-F TZB-</td> <td>SMD-F TZI-</td> <td>SHD-F TZO-</td> <td></td> <td></td> </tr> <tr> <td>Rotor</td> <td>SFR-F TZF-</td> <td>SMR-F TZJ-</td> <td>SHR-F TZP-</td> <td></td> <td></td> </tr> </tbody> </table>		Class 150 ANSI		Class 300 ANSI		Class 600 ANSI		Model	Code	Model	Code	Model	Code	Plain	SF-F TZA-	SM-F TZH-	SH-F TZN-			Flapper	SFF-F TZA-	SMF-F TZH-	SHF-F TZN-			Drip Tube	SFD-F TZB-	SMD-F TZI-	SHD-F TZO-			Rotor	SFR-F TZF-	SMR-F TZJ-	SHR-F TZP-											
Class 150 ANSI		Class 300 ANSI		Class 600 ANSI																																												
Model	Code	Model	Code	Model	Code																																											
Plain	SF-F TZA-	SM-F TZH-	SH-F TZN-																																													
Flapper	SFF-F TZA-	SMF-F TZH-	SHF-F TZN-																																													
Drip Tube	SFD-F TZB-	SMD-F TZI-	SHD-F TZO-																																													
Rotor	SFR-F TZF-	SMR-F TZJ-	SHR-F TZP-																																													
		<table border="1"> <thead> <tr> <th>Size</th> <th>Code</th> <th>Size</th> <th>Code</th> <th>Size</th> <th>Code</th> <th>Size</th> <th>Code</th> </tr> </thead> <tbody> <tr> <td>1/2"</td> <td>08</td> <td>1 1/2"</td> <td>16</td> <td>3"</td> <td>22</td> <td>6"</td> <td>28</td> </tr> <tr> <td>3/4"</td> <td>10</td> <td>2"</td> <td>18</td> <td>4"</td> <td>24</td> <td>8"</td> <td>30</td> </tr> <tr> <td>1"</td> <td>12</td> <td>2-1/2"</td> <td>20</td> <td colspan="4">CL150 & CL300 only</td> </tr> </tbody> </table>		Size	Code	Size	Code	Size	Code	Size	Code	1/2"	08	1 1/2"	16	3"	22	6"	28	3/4"	10	2"	18	4"	24	8"	30	1"	12	2-1/2"	20	CL150 & CL300 only																
Size	Code	Size	Code	Size	Code	Size	Code																																									
1/2"	08	1 1/2"	16	3"	22	6"	28																																									
3/4"	10	2"	18	4"	24	8"	30																																									
1"	12	2-1/2"	20	CL150 & CL300 only																																												
		<table border="1"> <thead> <tr> <th>Body Material</th> <th>Code</th> <th>Special Materials</th> <th>Code</th> </tr> </thead> <tbody> <tr> <td>Carbon Steel (WCB)</td> <td>C</td> <td>Hastelloy C (CW12MW)</td> <td>H</td> </tr> <tr> <td>316 SS (CF8M)</td> <td>S</td> <td>Alloy 20 (CN7M)</td> <td>A</td> </tr> <tr> <td>316L SS (CF3M)</td> <td>6</td> <td>Monel (M-35-1)</td> <td>M</td> </tr> <tr> <td>Bronze (B61)</td> <td>B</td> <td>PTFE Lined Ductile Iron</td> <td>R</td> </tr> </tbody> </table>		Body Material	Code	Special Materials	Code	Carbon Steel (WCB)	C	Hastelloy C (CW12MW)	H	316 SS (CF8M)	S	Alloy 20 (CN7M)	A	316L SS (CF3M)	6	Monel (M-35-1)	M	Bronze (B61)	B	PTFE Lined Ductile Iron	R																									
Body Material	Code	Special Materials	Code																																													
Carbon Steel (WCB)	C	Hastelloy C (CW12MW)	H																																													
316 SS (CF8M)	S	Alloy 20 (CN7M)	A																																													
316L SS (CF3M)	6	Monel (M-35-1)	M																																													
Bronze (B61)	B	PTFE Lined Ductile Iron	R																																													
		<p>Body Machining (1) Code</p> <p>Standard ASME Flange¹ 1 Note 1</p> <p>PFA Lined Body 2 RF Flanges - C, S, 6, H, A, M</p> <p>(Lined steel and 316 only) FF Flanges - B, R</p>																																														
		<table border="1"> <thead> <tr> <th>Indicator - Plain, Flapper, Drip Tube</th> <th>Code</th> <th>Indicator - Rotor</th> <th>Code</th> </tr> </thead> <tbody> <tr> <td>Plain (SF-F, SM-F, SH-F, DWF, DWM)</td> <td>0</td> <td>PTFE Rotor - Standard</td> <td>1</td> </tr> <tr> <td>316SS Flapper (-F) / 316 Drip (-D)</td> <td>1</td> <td>316SS Rotor⁽³⁾</td> <td>2</td> </tr> <tr> <td>PTFE Flutter (-F) / PTFE Drip (-D)⁽²⁾</td> <td>2</td> <td>Note 3: ONLY use when PTFE is not compatible with</td> <td></td> </tr> </tbody> </table> <p>Note 2: PTFE Indicators required for PFA Lined body, process or temperature exceeds 500F (260C)</p>		Indicator - Plain, Flapper, Drip Tube	Code	Indicator - Rotor	Code	Plain (SF-F, SM-F, SH-F, DWF, DWM)	0	PTFE Rotor - Standard	1	316SS Flapper (-F) / 316 Drip (-D)	1	316SS Rotor ⁽³⁾	2	PTFE Flutter (-F) / PTFE Drip (-D) ⁽²⁾	2	Note 3: ONLY use when PTFE is not compatible with																														
Indicator - Plain, Flapper, Drip Tube	Code	Indicator - Rotor	Code																																													
Plain (SF-F, SM-F, SH-F, DWF, DWM)	0	PTFE Rotor - Standard	1																																													
316SS Flapper (-F) / 316 Drip (-D)	1	316SS Rotor ⁽³⁾	2																																													
PTFE Flutter (-F) / PTFE Drip (-D) ⁽²⁾	2	Note 3: ONLY use when PTFE is not compatible with																																														
		<table border="1"> <thead> <tr> <th>Window Material</th> <th>Code</th> <th>Window Material</th> <th>Code</th> <th>Window Material</th> <th>Code</th> <th>Window Material</th> <th>Code</th> <th>Window Material</th> <th>Code</th> </tr> </thead> <tbody> <tr> <td>Tempered Boro Glass</td> <td>1 (T)</td> <td>Quartz Glass</td> <td>4 (Q)</td> <td>UniGlas w/ Steel Ring</td> <td>5 (U)</td> <td>UniGlas w/ Hast C Ring</td> <td>6 (U)</td> <td>UniGlas w/ Duplex Ring</td> <td>9 (U)</td> </tr> <tr> <td>T-Boro w/ Mica Shield</td> <td>D (T)</td> <td>Quartz w/ Mica Shield</td> <td>W (Q)</td> <td>CS UniGlas w/ Mica Shield</td> <td>H (U)</td> <td>HC UniGlas w/ Mica Shield</td> <td>N (U)</td> <td>Duplex UniGlas w/ Mica Shield</td> <td>S (U)</td> </tr> <tr> <td>T-Boro w/ PCTFE Shield</td> <td>F (T)</td> <td>Note: PCTFE (Generic term for KEL-F®)</td> <td></td> <td>CS UniGlas w/ PCTFE Shield</td> <td>L (U)</td> <td>HC UniGlas w/ PCTFE Shield</td> <td>P (U)</td> <td>Duplex UniGlas w/ PCTFE Shield</td> <td>U (U)</td> </tr> </tbody> </table>		Window Material	Code	Window Material	Code	Window Material	Code	Window Material	Code	Window Material	Code	Tempered Boro Glass	1 (T)	Quartz Glass	4 (Q)	UniGlas w/ Steel Ring	5 (U)	UniGlas w/ Hast C Ring	6 (U)	UniGlas w/ Duplex Ring	9 (U)	T-Boro w/ Mica Shield	D (T)	Quartz w/ Mica Shield	W (Q)	CS UniGlas w/ Mica Shield	H (U)	HC UniGlas w/ Mica Shield	N (U)	Duplex UniGlas w/ Mica Shield	S (U)	T-Boro w/ PCTFE Shield	F (T)	Note: PCTFE (Generic term for KEL-F®)		CS UniGlas w/ PCTFE Shield	L (U)	HC UniGlas w/ PCTFE Shield	P (U)	Duplex UniGlas w/ PCTFE Shield	U (U)					
Window Material	Code	Window Material	Code	Window Material	Code	Window Material	Code	Window Material	Code																																							
Tempered Boro Glass	1 (T)	Quartz Glass	4 (Q)	UniGlas w/ Steel Ring	5 (U)	UniGlas w/ Hast C Ring	6 (U)	UniGlas w/ Duplex Ring	9 (U)																																							
T-Boro w/ Mica Shield	D (T)	Quartz w/ Mica Shield	W (Q)	CS UniGlas w/ Mica Shield	H (U)	HC UniGlas w/ Mica Shield	N (U)	Duplex UniGlas w/ Mica Shield	S (U)																																							
T-Boro w/ PCTFE Shield	F (T)	Note: PCTFE (Generic term for KEL-F®)		CS UniGlas w/ PCTFE Shield	L (U)	HC UniGlas w/ PCTFE Shield	P (U)	Duplex UniGlas w/ PCTFE Shield	U (U)																																							
		<table border="1"> <thead> <tr> <th>Gasket Material</th> <th>Code</th> <th>Gasket Material</th> <th>Code</th> <th>Gasket Material</th> <th>Code</th> </tr> </thead> <tbody> <tr> <td>Neoprene</td> <td>1</td> <td>Fiber (IFG 5500)</td> <td>3</td> <td>Viton</td> <td>5</td> </tr> <tr> <td>Gylon 3545</td> <td>2</td> <td>Graphite</td> <td>4 (Q)</td> <td></td> <td></td> </tr> </tbody> </table>		Gasket Material	Code	Gasket Material	Code	Gasket Material	Code	Neoprene	1	Fiber (IFG 5500)	3	Viton	5	Gylon 3545	2	Graphite	4 (Q)																													
Gasket Material	Code	Gasket Material	Code	Gasket Material	Code																																											
Neoprene	1	Fiber (IFG 5500)	3	Viton	5																																											
Gylon 3545	2	Graphite	4 (Q)																																													
		<table border="1"> <thead> <tr> <th>Trim Material</th> <th>Code</th> <th>Trim Material</th> <th>Code</th> <th>Trim Material</th> <th>Code</th> </tr> </thead> <tbody> <tr> <td>T-Boro: Standard Steel Trim</td> <td>1 (T)</td> <td>Quartz: Standard Steel Trim</td> <td>4 (Q)</td> <td>UniGlas: Standard Steel Trim</td> <td>6 (U)</td> </tr> <tr> <td>T-Boro: All 316 SS Trim</td> <td>2 (T)</td> <td>Quartz: All 316 SS Trim</td> <td>5 (Q)</td> <td>UniGlas: All 316 SS Trim</td> <td>7 (U)</td> </tr> <tr> <td>T-Boro: STL Bolt / 316 Retainer</td> <td>9 (T)</td> <td>Quartz: STL Bolt / 316 Retainer</td> <td>G (Q)</td> <td>UniGlas: STL Bolt / 316 Retainer</td> <td>P (U)</td> </tr> <tr> <td>T-Boro: 316 Stud / STL Retainer</td> <td>A (T)</td> <td>Quartz: 316 Stud / STL Retainer</td> <td>H (Q)</td> <td>UniGlas: 316 Stud / STL Retainer</td> <td>R (U)</td> </tr> <tr> <td>T-Boro: B7 Stud/ 2H Nut STL Retainer</td> <td>B (T)</td> <td>Quartz: B7 Stud/ 2H Nut STL Retainer</td> <td>K (Q)</td> <td>UniGlas: B7 Stud/ 2H Nut STL Retaine</td> <td>S (U)</td> </tr> <tr> <td>T-Boro: B7 Stud/ 2H Nut 316 Retainer</td> <td>C (T)</td> <td>Quartz: B7 Stud/ 2H Nut 316 Retainer</td> <td>L (Q)</td> <td>UniGlas: B7 Stud/ 2H Nut 316 Retainer</td> <td>T (U)</td> </tr> </tbody> </table>		Trim Material	Code	Trim Material	Code	Trim Material	Code	T-Boro: Standard Steel Trim	1 (T)	Quartz: Standard Steel Trim	4 (Q)	UniGlas: Standard Steel Trim	6 (U)	T-Boro: All 316 SS Trim	2 (T)	Quartz: All 316 SS Trim	5 (Q)	UniGlas: All 316 SS Trim	7 (U)	T-Boro: STL Bolt / 316 Retainer	9 (T)	Quartz: STL Bolt / 316 Retainer	G (Q)	UniGlas: STL Bolt / 316 Retainer	P (U)	T-Boro: 316 Stud / STL Retainer	A (T)	Quartz: 316 Stud / STL Retainer	H (Q)	UniGlas: 316 Stud / STL Retainer	R (U)	T-Boro: B7 Stud/ 2H Nut STL Retainer	B (T)	Quartz: B7 Stud/ 2H Nut STL Retainer	K (Q)	UniGlas: B7 Stud/ 2H Nut STL Retaine	S (U)	T-Boro: B7 Stud/ 2H Nut 316 Retainer	C (T)	Quartz: B7 Stud/ 2H Nut 316 Retainer	L (Q)	UniGlas: B7 Stud/ 2H Nut 316 Retainer	T (U)			
Trim Material	Code	Trim Material	Code	Trim Material	Code																																											
T-Boro: Standard Steel Trim	1 (T)	Quartz: Standard Steel Trim	4 (Q)	UniGlas: Standard Steel Trim	6 (U)																																											
T-Boro: All 316 SS Trim	2 (T)	Quartz: All 316 SS Trim	5 (Q)	UniGlas: All 316 SS Trim	7 (U)																																											
T-Boro: STL Bolt / 316 Retainer	9 (T)	Quartz: STL Bolt / 316 Retainer	G (Q)	UniGlas: STL Bolt / 316 Retainer	P (U)																																											
T-Boro: 316 Stud / STL Retainer	A (T)	Quartz: 316 Stud / STL Retainer	H (Q)	UniGlas: 316 Stud / STL Retainer	R (U)																																											
T-Boro: B7 Stud/ 2H Nut STL Retainer	B (T)	Quartz: B7 Stud/ 2H Nut STL Retainer	K (Q)	UniGlas: B7 Stud/ 2H Nut STL Retaine	S (U)																																											
T-Boro: B7 Stud/ 2H Nut 316 Retainer	C (T)	Quartz: B7 Stud/ 2H Nut 316 Retainer	L (Q)	UniGlas: B7 Stud/ 2H Nut 316 Retainer	T (U)																																											

MOC Comments

- 1 View diameter changes for all sizes. New diameter is equal to or greater than the nominal pipe size.
- 2 Standard bolting in all units is now ASTM A354-BD with A194-2H nuts.

3
4
5
6



PENBERTHY SIGHT FLOW INDICATORS
ORDERING INFORMATION - NPT SIGHT FLOW SELECTION GUIDE

	Model	Size	Wetted Metal	Body	Indicator	Window	Gasket	Non-Wetted	Faceplate
									5

Class 150 ANSI		Class 300 ANSI		Class 600 ANSI	
Model	Code	Model	Code	Model	Code
Single Window					
Plain	SF TAJ-	SM TAZ-	SH TBZ-		
Flapper	SFF TAJ-	SMF TAZ-	SHF TBZ-		
Drip Tube	SFD TBJ-	SMD TEZ-	SHD TFZ-		
Rotor	SFR TCJ-	SMR TMZ-	SHR TNZ-		
Dual Window					
Plain	DWF TAX-	DWM TYA-			
Flapper	DWFF TAX-	DWMF TYA-			
Drip Tube	DWFD TBX-	DWMD TYE-			
Rotor	DWFR TCX-	DWMR TYM-			

150 psig		
Threaded Window	Model	Code
Plain	STW	TAA-
Flapper	STWF	TAA-
Drip Tube	STWD	TAB-
Rotor	STWR	TAC-

Size	Code	Size	Code	Size	Code	Size	Code
1/4"	04	1/2"	08	1"	12	1 1/2"	16
3/8"	06	3/4"	10	1 1/4"	14	2"	18

Body Material	Code	Special Materials	Code
Carbon Steel (WCB)	C	Hastelloy C (CW12MW)	H
316 SS (CF8M)	S	Alloy 20 (CN7M)	A
316L SS (CF3M)	6	Monel (M-35-1)	M
Bronze (B61)	B	PTFE Lined Ductile Iron	R

Body Machining (1) Code

Standard NPT	1
Optional Butt weld End	2
Optional Socket weld end	3

Indicator - Plain, Flapper, Drip Tube	Code	Indicator - Rotor	Code
Plain (SFF, SMF, SHF, DWFF, DWMF)	0	PTFE Rotor - Standard (SFR)	1
316SS Flapper (-) / 316 Drip (-D)	1	316SS Rotor ⁽³⁾	2
PTFE Flutter (-) / PTFE Drip (-D) ⁽²⁾	2		

Note 2: PTFE Indicators required for PFA Lined body, process or temperature exceeds 500F (260C)

Note 3: ONLY use when PTFE is not compatible with

Window Material	Code	Window Material	Code	Window Material	Code	Window Material	Code	Window Material	Code
Tempered Boro Glass	1 (T)	Quartz Glass	4 (Q)	UniGlas w/ Steel Ring	5 (U)	UniGlas w/ Hast C Ring	6 (U)	UniGlas w/ Duplex Ring	9 (U)
T-Boro w/ Mica Shield	D (T)	Quartz w/ Mica Shield	W (Q)	CS UniGlas w/ Mica Shield	H (U)	HC UniGlas w/ Mica Shield	N (U)	Duplex UniGlas w/ Mica Shield	S (U)
T-Boro w/ PCTFE Shield	F (T)	Note: PCTFE (Generic term for KEL-F®)		CS UniGlas w/ PCTFE Shield	L (U)	HC UniGlas w/ PCTFE Shield	P (U)	Duplex UniGlas w/ PCTFE Shield	U (U)

	Window Material	Code
Threaded Window (retainer)	Annealed Boro Glass	1
NPT Sight Flow Indicators	A-Boro w/ Mica Shield	5
	A-Boro w/ PCTFE Shield	7

Gasket Material	Code	Gasket Material	Code	Gasket Material	Code
Neoprene	1	Fiber (IFG 5500)	3	Viton	5
Gylon 3545	2	Graphite	4 (Q)		

Trim Material	Code	Trim Material	Code	Trim Material	Code
T-Boro: Standard Steel Trim	1 (T)	Quartz: Standard Steel Trim	4 (Q)	UniGlas: Standard Steel Trim	6 (U)
T-Boro: All 316 SS Trim	2 (T)	Quartz: All 316 SS Trim	5 (Q)	UniGlas: All 316 SS Trim	7 (U)
T-Boro: STL Bolt / 316 Retainer	9 (T)	Quartz: STL Bolt / 316 Retainer	G (Q)	UniGlas: STL Bolt / 316 Retainer	P (U)
T-Boro: 316 Stud / STL Retainer	A (T)	Quartz: 316 Stud / STL Retainer	H (Q)	UniGlas: 316 Stud / STL Retainer	R (U)
T-Boro: B7 Stud/ 2H Nut STL Retainer	B (T)	Quartz: B7 Stud/ 2H Nut STL Retainer	K (Q)	UniGlas: B7 Stud/ 2H Nut STL Retaine	S (U)
T-Boro: B7 Stud/ 2H Nut 316 Retainer	C (T)	Quartz: B7 Stud/ 2H Nut 316 Retainer	L (Q)	UniGlas: B7 Stud/ 2H Nut 316 Retainer	T (U)

	Trim Material	Code
Threaded Window (retainer)	Standard Brass Retainer	1
NPT Sight Flow Indicators	316 STS Retainer	2



PENBERTHY SIGHT FLOW INDICATORS
ORDERING INFORMATION - NPT SIGHT WINDOW SELECTION GUIDE

	Model	Size	Wetted Metal	Body	Window	Gasket	Non-Wetted	Tag Plate
								5

150 psig

Model	Code
WTSL	TJG-

Size	Code	Size	Code	Size	Code
1"	12	1 1/2"	16	2 1/2"	20
1 1/4"	14	2"	18	3"	22

Body Material	Code	Special Materials	Code
Carbon Steel	C	Hastelloy C (CW12MW)	H
316 (L) SS	S	Alloy 20 (CN7M)	A
Bronze	B	Monel (M-35-1)	M

Body Machining	Code
Standard NPT	1

Window Material	Code	Window Material	Code	Window Material	Code
Annealed Boro Glass	1	Tempered Boro Glass	3	Quartz Glass	4
A-Boro w/ Mica Shield	5	T-Boro w/ Mica Shield	D	Quartz w/ Mica Shield	W
A-Boro w/ PCTFE Shield	7	T-Boro w/ PCTFE Shield	F	Note: PCTFE (Generic term for KEL-F®)	

Gasket Material	Code	Gasket Material	Code	Gasket Material	Code
Neoprene	1	Fiber (IFG 5500)	3	Viton	5
Gylon 3545	2	Graphite	4		

Trim Material	Code
Standard Brass Retainer	1
316 STS Retainer	2

