

ACTUATORS AND DRIVES

WHY REXA?

Process control involves three fundamental elements – measurement, correction and control. The response, resolution, and stability of these factors determines the quality of the end product. With every electronic advancement made, measurement and data analysis capabilities continue to improve. However, the actual control of a process still requires movement of a mechanical device.

The REXA Xpac Electraulic™ Actuator is a superior positioning device well suited for critical control applications. The product is designed to control severe process conditions in harsh environments and provide high reliability. Electraulic™ Actuators and Drives provide the final control element capabilities to match the most sophisticated instrumentation and distributed control systems.

The Xpac is comprised of the mechanical subassembly and the electrical subassembly. The mechanical subassembly consists of a double acting hydraulic cylinder, position feedback sensor and an Electraulic™ Power Module. The power module is a unique, self-contained, sealed hydraulic pumping system which manages oil pressure and flow to and from the cylinder. The electrical subassembly consists of the power supplies, motor drivers and a dedicated microprocessor. The combination of these mechanical, hydraulic and electronic technologies gives the Xpac its state of the art capability.

SIMPLE

Electric operation

POWERFUL

Performance of hydraulics

FLEXIBLE

User configured control

HERE'S HOW IT WORKS:

The microprocessor converts the incoming control signal into a target position and compares it to the current position measured by the feedback sensor. If the target position and current position deviation exceeds the user-programmed deadband, the microprocessor will initiate motion to adjust actuator position. A bi-directional gear pump, driven by an electric motor, generates the hydraulic output necessary to move the actuator. System oil travels from the pump through a series of pilot operated check valves, known as the Flow Matching Valves (FMV's). The FMV's manage oil transfer out of one side of the cylinder and into the other. This drives the actuator to the target position. Once the target position is reached the motor and pump stop, and the FMV's close, hydraulically locking the cylinder in place. The motor will only turn on again if the signal deviation exceeds the deadband and a position change is required.

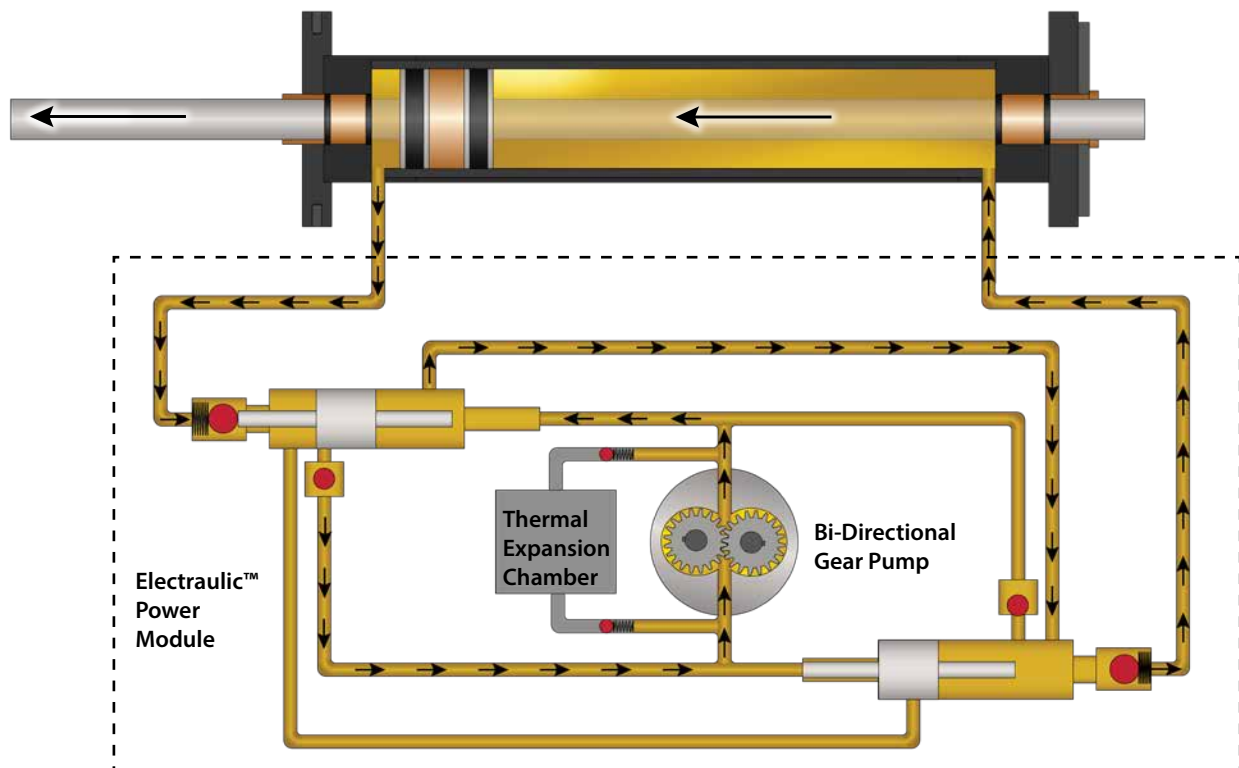

OIL & GAS APPLICATIONS

Midstream

- Pump Station Pressure Control
- Meter Back Pressure and Balance Control
- Terminal Inlet Pressure Control
- Pump Recycle / Min. Flow Control
- Well Head Shut Down
- Extraction Well



Downstream

- Separator Level Control
- Water / Steam Injection
- Blow-off Valve / Snort Valves
- Flue Gas Valves
- ESDV's / EIV's
- IDF, FDF Damper Control
- Fluid Catalytic Cracker Valves
- Wet Gas Compressor Control
- Overhead Pressure Letdown
- Spent and Regenerated Catalyst Slide Valves



POWER GENERATION APPLICATIONS

Combined Cycle

- Sky Valve Control
- Turbine Bypass Systems / Hot Reheat Valves
- Feedwater Control
- Feedwater Recirculation Valves
- Superheat / Reheat Spray Valves



Geothermal

- Well Head Control
- Hotwell Level Control
- Separator Level Control

Fossil-Fired Power

- FD/ID Damper Drives
- Primary / Secondary Air Damper Drives
- Burner Tilts Nozzle Control
- Sootblower Header Control
- Supercritical Start Up Valves
- Main Steam Drain Valves



ROTATING EQUIPMENT APPLICATIONS

- Steam Turbine Governors
- Steam Turbine Pilot Valves
- Steam Turbine Extraction
- Inlet Guide Vane Control
- Compressor Antisurge / Recycle
- Water / Steam Injection Valves
- Fuel Gas Valves
- Fuel Oil Valves
- Gas Turbine Inlet Bleed Heat
- Scoop Tubes



WATER & WASTEWATER APPLICATIONS

Water

- Intake Pump Discharge Control
- Raw Water Influent Control
- Filter Control
- Ozone Control
- High Service Pump Discharge Control
- Distribution Control



Wastewater

- Collections System Control
- Sewerage Pump Control
- Main Influent Headworks Gates
- Aeration and Blower Control
- Sludge Control
- UV Gate Control



METALS & MINING APPLICATIONS

Mining

- Flotation Cell Pulp Level Control
- Clave Inlet / Discharge Isolation
- Clave Pressure Letdown
- ILS Pump Station Flow Control
- Acid Flow Control for Leaching
- Cement Kiln Feed Control



Metals

- Coke Oven Collection Main
- Recycle Gas Pressure
- BFG Pressure to Boiler Control
- Mixed Gas Pressure
- Blast Furnace Wind Turbo Blower Speed Control
- Reheat Furnace Pressure Control



MECHANICAL SUBASSEMBLY

Oil Level Indication

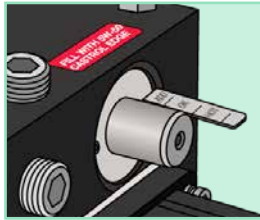

Linear Position Feedback

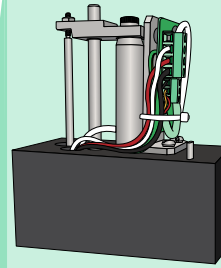

A position sensor is directly mounted to one end of the cylinder shaft. The direct mount of the sensor eliminates the potential for hysteresis. Valve-stem motion is constantly monitored and relayed by the position transmitter.

Electraulic Power Module

Key components of the Power Module include the 100% duty cycle motor, bi-directional gear pump and Flow Matching Valves. This simple and compact design features a closed loop, positive pressure hydraulic system which eliminates the need for active reservoirs and filters.

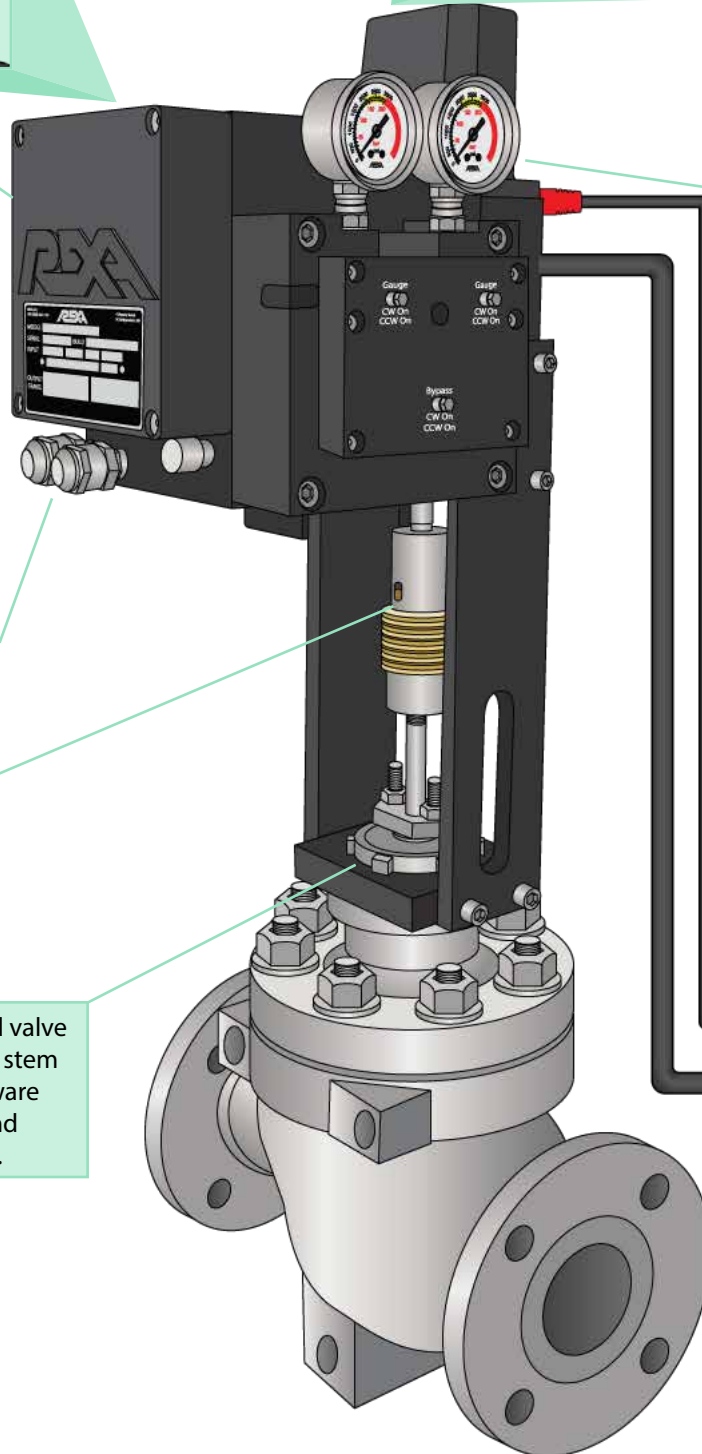

Pressure Gauges

Real-time output indication.

Output Limit Protection

Elastic Coupling

Linear valve seat load indication.

Interconnect Cables

Color-coded cables are available with the quick release option. Extended lengths (up to 700ft / 213m) enable remote mounting for the electrical subassembly.

Valve Mounting

Custom-engineered valve adaptation bracket, stem coupling and hardware available for new and retrofit installations.

ELECTRICAL SUBASSEMBLY

Electrical Components



Key electrical subassembly components include the motor driver, CPU board, power board and an interconnect board with warning, alarm and position indication relays. The layout features a guided backplane.

Flip-Up Display Cover

Protects the keypad from wind-driven debris and harsh sun exposure.

Status Indication



Displays operation mode, status, current position, diagnostic warnings, and alarms. A real-time clock provides event time and date stamping.

Display and Keypad

Simple, user-friendly push-button calibration.



Feedback Cable

Motor Cable

Control System I/O

Control signal
Digital communication
Warning and alarm relay out

Construction

316 Stainless Steel
NEMA 4X

Input Power

LINEAR ACTUATORS

Xpac Linear Actuators utilize a double acting hydraulic cylinder driven by one or more Electraulic™ Power Modules. The Linear Actuator is configurable to suit a wide variety of control and isolation applications across many industries (see page 3). For both new equipment and retrofit scenarios, REXA manufactures the mounting bracket and stem adapter to fit any style valve, gate, damper or turbomachinery.

Linear Feedback

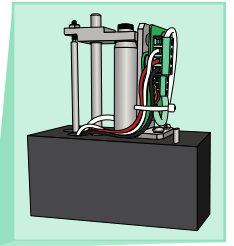

Linear Details

- Electraulic™ Power Module motor and pump system
- Double rod cylinder design allows even oil displacement
- Position feedback sensor attached directly to cylinder shaft
- Valve, gate or machinery adaptation hardware customized per application
- Available thrusts: 2,000 lbf to 275,000 lbf*
- Stroke ranges: ¾ inch to over 120 inches*

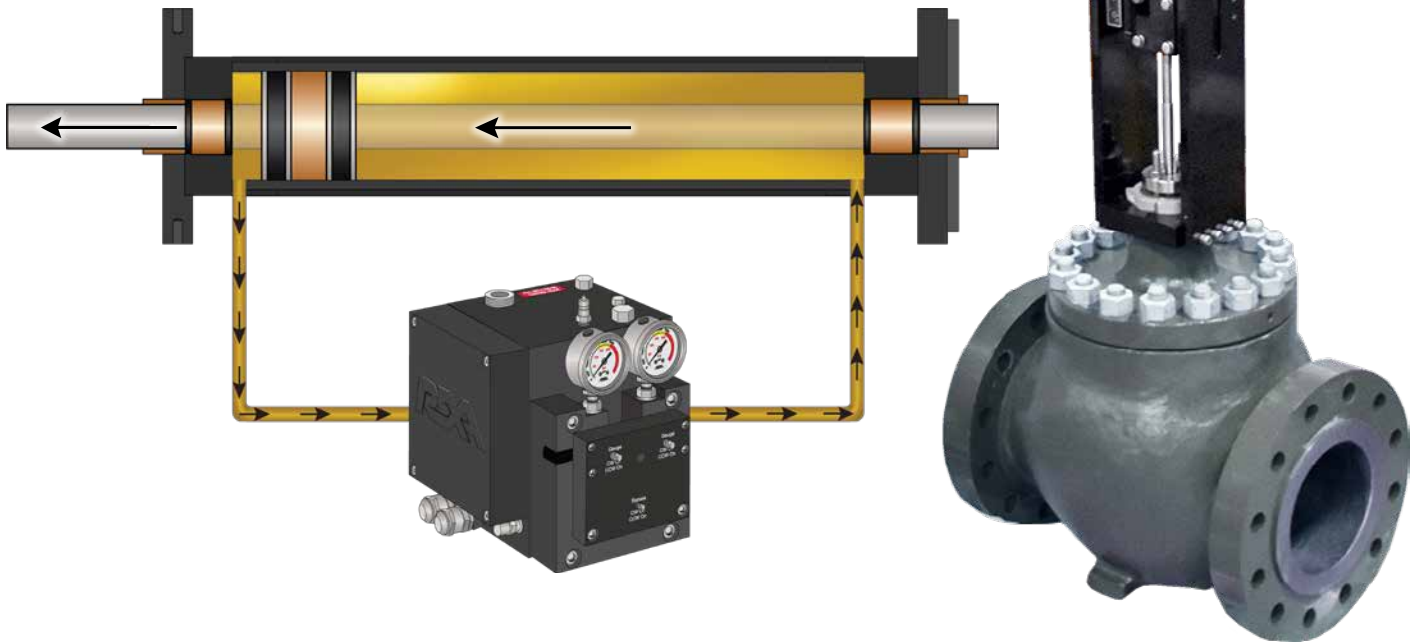

Linear Actuator Stroke Rates (sec / in)

Thrust lbf (N)	Power Module Type							
	B	C	½D / 2C	D	2D	D,P9	D,P20	D,P40
2000 (8896)	6	2	1	0.5	N/A	N/A	N/A	N/A
4000 (17792)	12	4	2	1	0.5	N/A	N/A	N/A
5000 (22241)	15	5	2.5	1.3	0.6	0.3	N/A	N/A
10000 (44482)	30	10	5	2.5	1.3	0.6	0.3	CF
15000 (66723)	N/A	15	7.5	3.8	1.9	0.8	0.4	CF
20000 (88964)	N/A	20	10	5	2.5	1.2	0.6	0.3
30000 (133447)	N/A	30	15	7.5	3.8	1.7	0.8	0.4
40000 (177928)	N/A	N/A	21	10.5	5.3	2.3	1.2	0.6
60000 (266893)	N/A	N/A	N/A	15.5	7.8	3.4	1.7	0.8
80000 (355858)	N/A	N/A	N/A	20.5	10.3	4.6	2.3	1.1
120000 (533787)	N/A	N/A	N/A	30	15	6.7	3.4	1.7

* Larger thrusts and longer stroke ranges are available

ROTARY ACTUATORS AND DAMPER DRIVES

Xpac Rotary Actuators and Damper Drives are designed with a rack and pinion hydraulic cylinder driven by one or more Electraulic™ Power Modules. The Rotary Actuator is commonly used on ball and butterfly valve applications across numerous industries (see page 3). The Damper Drive, which utilizes a mounting base and drive arm, is commonly used on fan and stack dampers, burner tilts and other combustion control applications. REXA manufactures the valve mounting bracket, stem adapter or drive base and drive arm to suit any valve or damper type.

Rotary & Drive Feedback



Rotary and Drive Details

- Electraulic™ Power Module motor and pump system
- Dual opposed cylinders driving a rack and pinion assembly allows even oil displacement
- Position Feedback sensor is attached directly to cylinder pinion
- Valve or damper adaptation hardware customized per application
- Available torques: 2,500 in-lbf to 1,500,000 in-lbf*
- Rotation: 90°, 120°, 180°, or 270°*

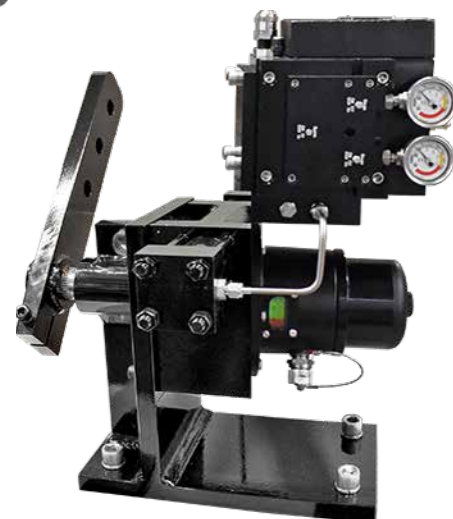
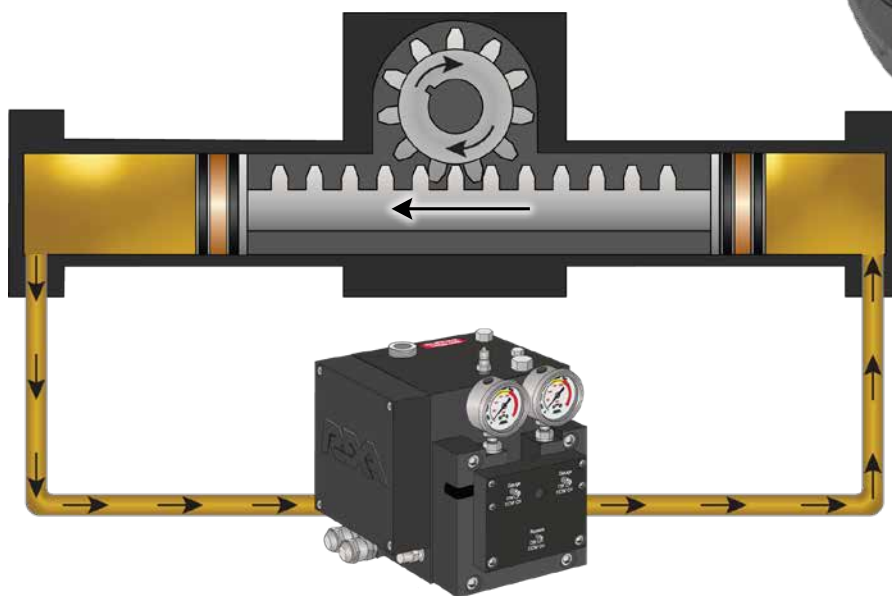

Rotary Actuator and Damper Drive Rotation Rates (sec / per 90°)

Torque in-lbf (N·m)	Power Module Type							
	B	C	½D / 2C	D	2D	D,P9	D,P20	D,P40
2500 (282)	15	5	2.5	1.3	N/A	N/A	N/A	N/A
5000 (565)	30	10	5	2.5	1.3	N/A	N/A	N/A
10000 (1130)	53	18	9	4.5	2.3	1	NA	N/A
20000 (2260)	105	36	18	9	4.5	2	1	N/A
50000 (5650)	N/A	92	46	23	11.5	5.1	2.6	1.2
100000 (11300)	N/A	N/A	92	46	23	10.2	5.1	2.4
200000 (22597)	N/A	N/A	NA	89	44.5	20	10	4.7
400000 (45194)	N/A	N/A	NA	178	89	40	20	9.3

* Larger torques and wider degrees of rotations are available

MANUAL OVERRIDES

REXA Actuators and Drives can be operated with a manual override when electric power is unavailable.

Declutchable Handwheel / Drill Drive

(Attached to the end of the motor)

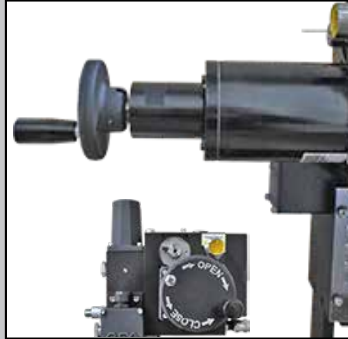

Manual Pump

(Hydraulically connected to the actuator cylinder)

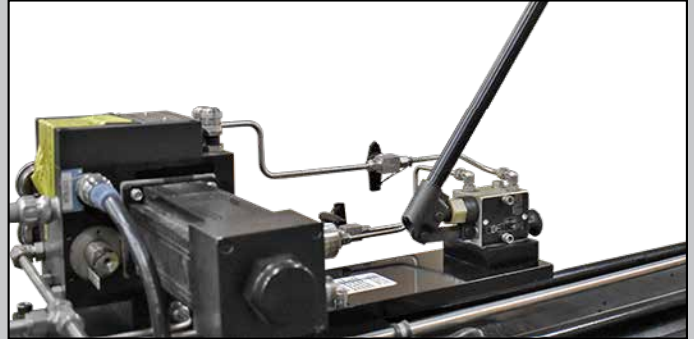

FAIL-SAFE CAPABLE

Many critical applications require an end of stroke fail-safe position. The fail-safe condition may be initiated by a loss of power, introduction / removal of a trip signal or a combination of both.

Spring fail-safe positioning involves a coil spring placed in series with the hydraulic cylinder. When a fail-safe condition is initiated, an isolation solenoid opens the hydraulic circuit allowing the spring to move the driven device to the specified position.

Accumulator fail-safe systems include a nitrogen charged, piston-type accumulator. During normal operation, a solenoid isolates the stored energy of the accumulator from the main hydraulic circuit. When a fail-safe condition is initiated, the solenoid opens to release the accumulator pressure which moves the driven device to the specified position. On restoration of power, the Electraulic™ Power Module recharges the accumulator to a target pressure setpoint.

Spring and accumulator fail-safe systems can be configured to trip full stroke / rotation in 200mS.



SURGE CONTROL

Process upset conditions may require an actuator to make a large and fast position change beyond the speed capability of the standard Electraulic™ Power Module. REXA Actuators equipped with a spring or accumulator can utilize the stored energy within the fail-safe system to provide these large step, high-speed position changes. The Surge Control feature enables these rapid step changes to any position within the actuator's calibrated stroke or rotation. Tuning parameters, accessed through the display and keypad, allow the user to define exactly when, and under what conditions, the feature is enabled.



BOOSTER PUMPS



Booster pump systems utilize a standard Electraulic™ Power Module paired with an auxiliary large capacity motor and pump. This dual pump configuration combines fine control capability and fast speeds on high output actuators. The power module provides fine control during small position changes, while the booster pump is utilized during large position changes. Control parameters, accessed through the display and keypad, allow the user to adjust booster pump performance for a given application.

Booster Pump Sizes: DP9, DP20, DP40

VALVE SEATING INDICATION

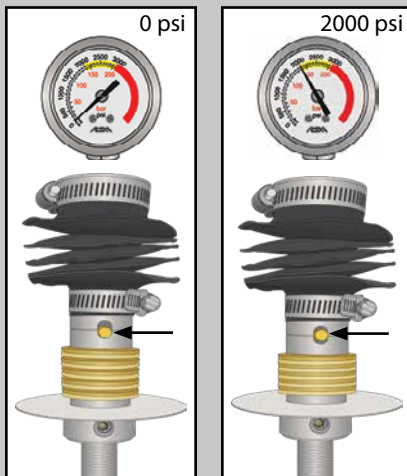

Elastic Coupling: For linear control valves that require a specific seat load to ensure shutoff, Xpac Linear Series Actuators can be equipped with an elastic coupling. The elastic coupling is comprised of pre-compressed Belleville washers and sits between the valve and actuator stems. As the valve plug engages with the seat, the washers compress and the indicator pin slides into position. The dual purpose of the elastic coupling is to indicate positive seat load and compensate for valve stem thermal expansion.

Seat Load Cylinder: A seat load cylinder (SLC) is used on actuator systems that are too large for elastic couplings. The SLC is a spring opposed cylinder hydraulically connected to the actuator cylinder. When the actuator cylinder reaches a hard stop (valve seat), pressure builds in the SLC. The pressure compresses the spring until the SLC reaches the calibrated seated position. An externally viewable indicator provides visual confirmation that the valve is seated.

PARTIAL STROKE TESTING

Partial Stroke Testing (PST) is used to verify the actuator is capable of performing its intended safety function. REXA Actuators are designed to support proof test intervals for SIL applications when PST is implemented. During a partial stroke test the customer's control system monitors the position transmitter to ensure the actuator successfully performed its function. PST monitoring can be programmed and scheduled with the REXA Graphical User Interface.

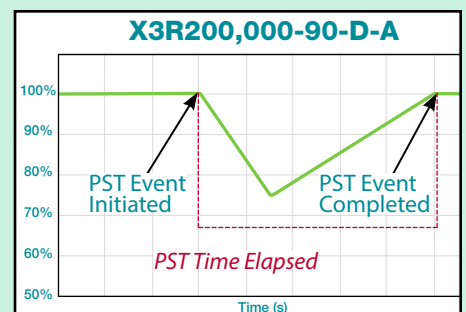

REDUNDANT CONSTRUCTION



The Xpac Actuator has exceptional reliability and design life. In addition to performance gains attributed to the use of Electraulic™ Actuation, many customers choose REXA specifically for its reliability.

Critical applications require additional reliability to maximize plant uptime and reduce the risk of an unplanned shutdown or a potential safety issue. Redundancy is the commonly chosen method to keep these systems operating. Choosing a redundant REXA system will increase actuator reliability to a value over 99.9%.

CUSTOM CONFIGURATIONS

Not all plant facilities are the same. Plant age, OEM installed equipment, and operational criteria play a role in every plant's unique requirements. Tight installation envelopes, harsh ambient conditions, vibration concerns, and the need for ground level manual operation can all be accommodated with unique packaging or remote mounting of components. With a modular approach to actuation, custom REXA configurations can meet any users' specific needs.



GRAPHICAL USER INTERFACE

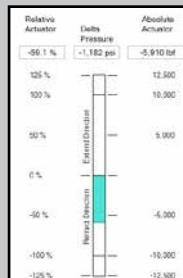

A PC-based optional user interface allows the customer to view calibration parameters, current position, warning and alarm conditions, event time and date stamps, motor starts, actuator strokes, cylinder differential pressure and other diagnostic information. Certain diagnostic information requires availability of the appropriate optional construction. All reports are downloadable via PC into a spreadsheet for review and analysis. System calibration files and service notes can be saved and uploaded, to and from specific actuators.

MODEL NUMBER

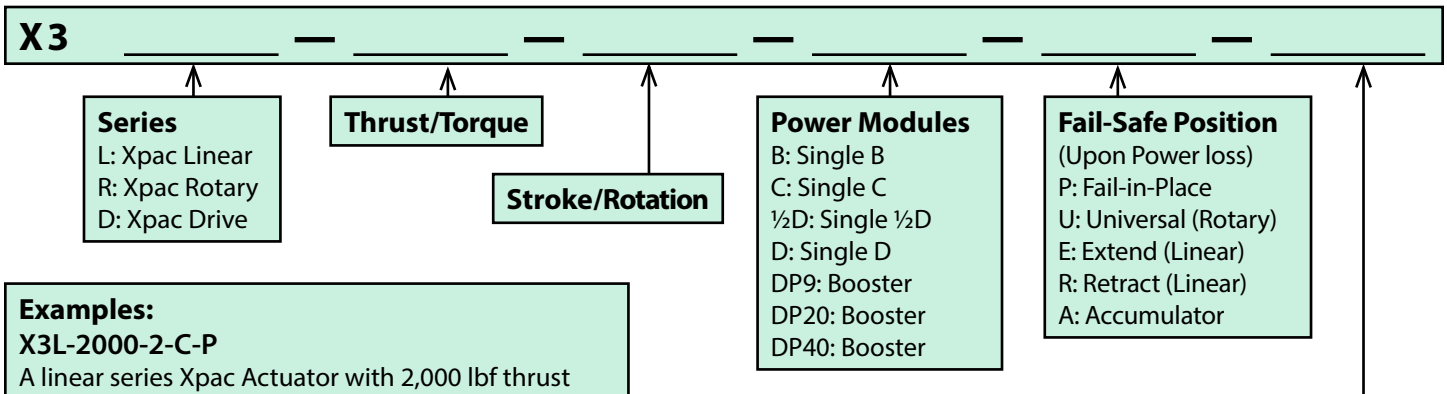

Examples:

X3L-2000-2-C-P

A linear series Xpac Actuator with 2,000 lbf thrust and a C power module. Any stroke up to 2 inches. Fail-in-place upon loss of power.

X3R-100000-90-2D-A

A rotary series Xpac Actuator with 100,000 in-lbf torque and dual D power module. Any rotation up to 90 degrees. Accumulator fail-safe upon loss of power.

Hazardous Area Code

- C1: Division 1 / Zone 1 Actuator Only
- C2: Division 2 / Zone 2 Actuator and Electronics
- C5: Division 1 / Zone 1 Actuator with Division 2 / Zone 2 Electronics
- C6: Division 1 / Zone 1 Actuator and Electronics
- CA: Division 2 / Zone 2 Actuator Only

PRODUCT SPECIFICATIONS*

PERFORMANCE

Deadband: Adjustable from 0.05% to 5.0%

Positioning Accuracy:

<0.15% of full stroke

Linearity: <0.05% of full stroke

Repeatability: <0.10% of full stroke

Response (Corner Frequency):

1.5 Hz for B and C size power modules

>5 Hz for ½D and D size power modules

Deadtime: 50 - 70 ms

Duty Cycle: 100% full modulating

MECHANICAL SUBASSEMBLY

Outputs:

Linear: 2,000 lbf to 275,000 lbf

(8,896 N to 1,223,260 N)

Rotary/Drive: 2,500 in-lbf to 1,500,000 in-lbf

(282 N•m to 169,477 N•m)

Stroke Range: ¾ in to 120 in

Rotation Range: 90°, 120°, or 270°

Ambient Temperature Range:

Linear, Rotary, and Drive: -40°F to 250°F (-40°C to 121°C)

Oil Type Options:

Castrol Edge 5W-50 (STD)

Mobile HVI 26 (OPT)

RSC FUTERRA HF 100 (OPT)

Motor Types:

Stepper (B and C)

Servo (½D, D, DP9, DP20, and DP40)

Feedback: Thin film potentiometer or non-contacting potentiometer (dependent on temperature).

ELECTRICAL SUBASSEMBLY

Display and Controls: Four line vacuum fluorescent display, five push button keypad. Parameters stored in non-volatile memory.

Control Signal:

Analog: 4-20 mA

HART Compatible

Ambient Temperature Range:

Stepper: -40°F to 140°F (-40°C to 60°C)

Servo: -40°F to 120°F (-40°C to 50°C)

POWER REQUIREMENTS

Voltages:

B, C, and ½D Module: 115 VAC (STD), 230 VAC (OPT), 1Ø

D Module: 115 VAC (OPT), 230 VAC (STD), 1Ø

DP9, DP20 and DP40 Module: 230 VAC (STD), 3Ø

Consumption (Steady-State):

5 watts @ ambient temperatures > 50° F (10°C)

50 watts @ ambient temperatures < 50° F (10°C)

Consumption (Maximum):

B Module: 500 watts

C Module: 1100 watts

½D and D Module: 2400 watts

DP9 Module: 9000 watts

DP20 Module: 12000 watts

DP40 Module: 21000 watts

COMPLIANCE AND CERTIFICATIONS

Environmental Rating:

NEMA 4X

IP 66

CSA_{US}:

Class I Division 2 Groups A, B, C and D

Class I Division 1 Groups C and D

ATEX:

II 3G Ex nA IIC T3 Gc

II 2G Ex db [ia IIC] IIB T3

IECEX:

Ex nA IIC T3 Gc

EX db [ia IIC] IIB T3

INMETRO:

Ex nA IIC T3 Gc

EX db [ia IIC] IIB T3

Fundamental Safety Rating:

SIL 3 Capable

CE Compliant



* Performance capabilities may vary by model. REXA Actuators and Drives are custom engineered for every application. This product catalog summarizes the wide range of REXA product capabilities. Power requirements, ambient temperatures and hazardous area certifications may affect availability of certain model configurations. Please contact the REXA factory to receive a quote for an actuator solution specific to your needs. REXA is continually improving the design of its products. Specifications are subject to change.



REXA, Inc.

4 Manley Street

W. Bridgewater, MA 02379, USA

T: +1 508.584.1199

www.rexa.com



MADE IN USA

ISO 9001

Xpac_3-02/19